

UDC 621:333

## INSTANTANEOUS POWER SPECTRA ANALYSIS AS A METHOD FOR DIAGNOSTIC THE ROTOR AND STATOR FAULTS OF INDUCTION MOTOR

**D. Mamchur**

Kremenchuk Mykhailo Ostrohradskyi National University  
vul. Pershotravneva, 20, Kremenchuk, 39600, Ukraine. E-mail: dm@kdu.edu.ua

Presented proposed to make diagnostics of induction motor technical conditions basing on instantaneous power spectra analysis. This method is attractive because of measuring simplicity and reliable results comparing to other known methods. In this paper mathematical equations, which determines correlation between faulty frequencies in power signal and most frequently caused fault types is presented. Also experimental results of verification this method using laboratory equipment and tested motor with artificial damages is presented. Test results proved reliability of proposed method and possibility of separating simultaneously presented faults by analyzing motor power spectra. Presented theoretical results could be implemented in industrial applications for producing reliable and cheap diagnostic system for small and medium power induction motors.

**Key words:** diagnostics, induction motor, power signal analysis.

## АНАЛІЗ СПЕКТРУ МИТТЄВОЇ ПОТУЖНОСТІ ЯК МЕТОД ДІАГНОСТИКИ ПОШКОДЖЕНЬ РОТОРА І СТАТОРА АСИНХРОННОГО ДВИГУНА

**Д. Г. Мамчур**

Кременчуцький національний університет імені Михайла Остроградського  
вул. Першотравнева, 20, м. Кременчук, 39600, Україна. E-mail: dm@kdu.edu.ua

Запропоновано метод діагностики технічного стану асинхронних двигунів на основі аналізу спектра сигналу миттєвої потужності. Даний метод є привабливим завдяки простоті вимірювань сигналів, необхідних для аналізу, а також більш надійними результатами діагностики порівняно з іншими відомими методами. Надано математичні вирази, що встановлюють зв'язок між частотами дефектів у сигналі потужності та найбільш розповсюдженими типами дефектів. З метою підтвердження працездатності запропонованого метода показано експериментальні результати, отримані на лабораторному обладнанні та тестових двигунах зі штучно створеними пошкодженнями. Результати експериментів підтвердили надійність запропонованого методу та можливість розділення одночасно наявних різних типів дефектів на основі аналізу спектра потужності двигуна. Отримані теоретичні результати можуть бути застосовані у промисловості при створенні надійних і недорогих систем діагностики асинхронних двигунів середньої й малої потужності.

**Ключові слова:** діагностика, асинхронний двигун, аналіз сигналу потужності.

**PROBLEM STATEMENT.** Electrical machines, especially induction motors (IM) are most widely used energy consumers and energy converters for different station. This may result in significant pecuniary losses because of repair operations and idle time. Thus, timely diagnostics of incipient faults of electrical motors, and especially induction motors, is a very important task. To achieve this effect the on-line IM diagnostic systems are being developed.

Different reviews [1–3] showed that most frequently caused IM faults are the following: the bearings faults (32–52%), stator windings faults (15–47%), rotor bars/rings (less than 5%), shaft or coupling faults (about 2%), faults caused by external devices (12–15%), other faults (10–15%). For detection of bearings faults usually use well-developed and widely used methods of vibration diagnostics [4–5]. Thus, this work deals with incipient faults detection of stator and rotor. Most common rotor faults are the rotor-to-stator eccentricity and the rotor bar breaks. Most common stator defects are the short circuits in windings and also the windings parametrical asymmetry.

There is a range of methods for incipient fault detection. Widely used are monitoring of mechanical vibrations, currents, reverse sequence pole and partial charg-

industrial applications. In spite of a very simple and reliable construction, there happen IM sudden failures which may lead to failing of the whole work es. The aim of these methods is to detect deviations in signal spectra.

Well-known IM incipient faults detection methods are successfully used for large and medium machines. However, there are some limitations for usage of these methods applying to low-voltage machines, because of economical reasons and sensors size [6].

In this work it is proposed to make IM diagnostic basing on instantaneous power signal analysis. Such analysis gives comprehensive information about current technical conditions of motor. It allows one to make conclusion about possibility of usage motor with rated load or necessity to reduce motor load in order to prolong its lifetime.

**EXPERIMENTAL PART AND RESULTS OBTAINED.** The instantaneous power spectra analysis allows avoiding shortcomings of analyzed diagnostic methods [7–11]. Instantaneous power spectra analysis allows both detection of fault presence and estimation of damage level by analysis of proper harmonic value. Thus, it allows one to make estimation of the energy of a fault and the correlation of this energy to additional damage of IM parts under influence of additional vibra-

tions caused by proper harmonic. Moreover, the instantaneous power spectra analysis allows analyzing of IM operation modes under significant nonlinearity, when it is incorrect to use superposition principle for current harmonics [12]. Also, instantaneous power spectra analysis is more reliable, it is less dependent on noise, and gives additional harmonic components for analysis [7–11].

The instantaneous power is defined as

$$p(t) = u(t)i(t),$$

where  $u(t)$  is the phase voltage;  $i(t)$  is the input phase current.

In case of a healthy motor running with a constant speed and fed from ideal supply, the expressions of the phase voltage  $u(t)$ , phase current  $i(t)$  and instantaneous power, are following [13]:

$$\begin{aligned} u(t) &= \sqrt{2}U_1 \cos(\omega t); \\ i(t) &= \sqrt{2}I_1 \cos(\omega t - \varphi); \\ p(t) &= u(t)i(t) = 2U_1I_1 \cos(\omega t) \cos(\omega t - \varphi) = \\ &= 2U_1I_1 \cos(\omega t) [\cos(\omega t) \cos(\varphi) + \sin(\omega t) \sin(\varphi)] = \\ &= U_1I_1 \cos(\varphi) + U_1I_1 \cos(\varphi) \cos(2\omega t) + \\ &\quad + U_1I_1 \sin(\varphi) \sin(2\omega t), \end{aligned} \quad (1)$$

where  $U_1, I_1$  are RMS values of phase voltage and current, respectively;  $\omega = 2\pi f$  is the angular frequency, where  $f$  is the supply frequency;  $\varphi$  is the motor load angle.

In difference to current spectra, which contain only the fundamental component at the frequency  $f$ , the instantaneous power spectra has an average power component  $U_1I_1 \cos(\varphi)$  and fundamental component at frequency  $2f$ .

In order to make comprehensive analysis of IM defects, it is necessary to analyze total instantaneous power of three phases, which is the sum of phase instantaneous powers:

$$p_{tot}(t) = u_A(t)i_A(t) + u_B(t)i_B(t) + u_C(t)i_C(t).$$

Total three phase instantaneous power contains more diagnostic information. It allows to analyze not only defects which causes phase signals modulations, but also allows analyze defects which caused by motor or supply asymmetry and which leads to phase signals asymmetry. In case of symmetrical motor, signal of total three phase instantaneous power contain only dc component. Thus, every kind of motor fault or drive system asymmetry leads to appearance unique harmonic components which could be used for certain detection of fault type.

As it was mentioned above, rotor bar break causes sinusoidal modulations of the stator current. By analogy to [6], modulated phase current can be expressed as

$$\begin{aligned} i_m(t) &= i(t)[1 + I_m \cos(2\pi f_{bb}t)] = \\ &= i(t) + \frac{\sqrt{2}}{2} I_1 I_m \left[ \begin{aligned} &\cos(2\pi(f - f_{bb})t - \varphi) + \\ &+ \cos(2\pi(f + f_{bb})t - \varphi) \end{aligned} \right], \end{aligned} \quad (2)$$

where  $I_m$  is the modulation index;  $f_{bb}$  is the modulating frequency;  $s$  is the slip.

According to expression (2), phase current spectra, in addition to fundamental component, contain two sideband components at frequencies  $f - f_{bb}$  and  $f + f_{bb}$  (Fig. 1,a).

Expression for modulated phase instantaneous power is the following:

$$\begin{aligned} p_m(t) &= i_m(t)u(t) = \\ &= p_0(t) + \frac{1}{2} I_1 I_m U_1 \cos[2\pi(2f - f_{bb})t - \varphi] + \\ &\quad + \frac{1}{2} I_1 I_m U_1 \cos[2\pi(2f + f_{bb})t - \varphi] + \\ &\quad + I_1 I_m U_1 \cos(\varphi) \cos(f_{bb}t). \end{aligned} \quad (3)$$

This expression shows that phase instantaneous power spectra, besides dc component  $p_0(t)$  and two sideband components at frequencies  $2f - f_{bb}$  and  $2f + f_{bb}$ , contains an additional component  $I_1 I_m U_1 \cos(\varphi) \cos(f_{bb}t)$  at the modulation frequency  $f_{bb}$ , which is an additional diagnostic parameter (Fig. 1,b).

In case of symmetrical drive system there is compensation of harmonic components in 3-phase instantaneous power spectra. Thus, it contains only dc component and component at frequency  $2f + f_{bb}$  (Fig. 1,c).

Any kind of drive system asymmetry leads to appearance additional harmonic components in 3-phase instantaneous power spectra at the modulation frequency  $f_{bb}$ , sideband component at frequency  $2f + f_{bb}$ , and fundamental component at frequency  $2f$  (Fig. 1,c).

In case of air gap eccentricity, current frequencies lead to modulation of phase current:

$$\begin{aligned} i_{eccen}(t) &= i(t) + \\ &+ \frac{\sqrt{2}}{2} I_1 \sum_{k=1}^K \left[ \begin{aligned} &I_{e1k} \cos(2\pi(f - kf_r)t - \alpha_{e1k}) + \\ &+ I_{e2k} \cos(2\pi(f + kf_r)t - \alpha_{e2k}) \end{aligned} \right] \end{aligned} \quad (4)$$

where  $I_{e1k}, \alpha_{e1k}$  are the current amplitudes and the initial phase angle for frequencies  $f - kf_r$ ;  $I_{e2k}, \alpha_{e2k}$  are the current amplitudes and the initial phase angle for frequencies  $f + kf_r$ .

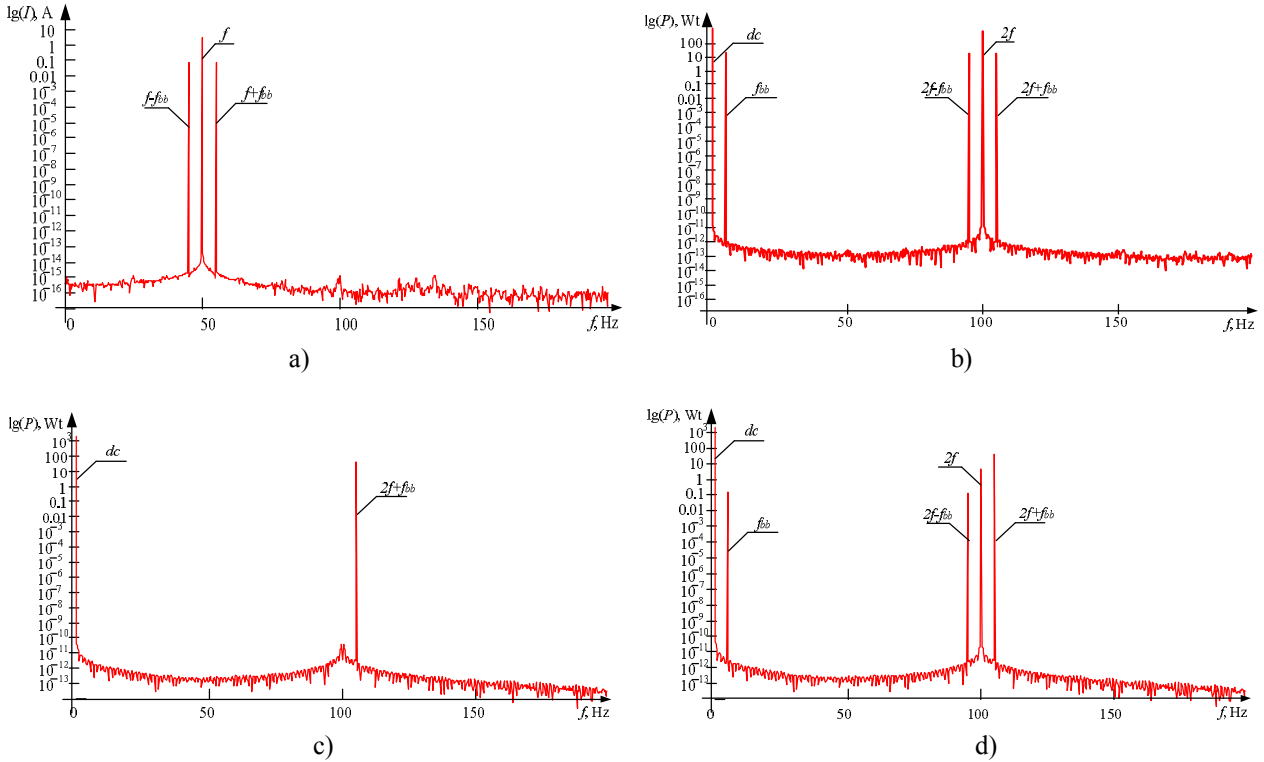

Figure 1 – Spectra of phase current (a) and phase power (b) for motor with rotor bar breaks and 3-phase power spectra for symmetrical (c) and not symmetrical (d) drive system with rotor bar breaks

In this case the expression for phase instantaneous power of a motor operating under air gap eccentricity is the following:

$$p_{eccen}(t) = i_{eccen}(t)u(t) = p_0(t) + \frac{1}{2} I_1 U_1 \sum_{k=1}^K \left[ \begin{aligned} & I_{e1k} \cos[2\pi(2f - kf_r)t - \alpha_{e1k}] + \\ & I_{e2k} \cos[2\pi(2f - kf_r)t - \alpha_{e2k}] + \\ & I_{e1k} \cos(\alpha_{e1k}) \cos(kf_r t) + \\ & I_{e2k} \cos(\alpha_{e2k}) \cos(kf_r t) \end{aligned} \right] \quad (5)$$

Air gap eccentricity leads to appearance in phase power spectra sideband components at frequencies  $2f - kf_r$  and  $2f + kf_r$ , and additional harmonic components at frequencies  $kf_r$ .

The vibrations caused by bearings damage leads to current modulation at the following frequencies:

$$i_{brg}(t) = i(t) + \frac{\sqrt{2}}{2} I_1 \sum_{k=1}^K \left[ \begin{aligned} & I_{b1k} \cos(2\pi(f - kf_{brg})t - \alpha_{b1k}) + \\ & I_{b2k} \cos(2\pi(f + kf_{brg})t - \alpha_{b2k}) \end{aligned} \right],$$

where  $I_{b1k}, \alpha_{b1k}$  are the current amplitudes and the initial phase angle for frequencies  $f - kf_{brg}$ ;  $I_{b2k}, \alpha_{b2k}$  are the current amplitudes and the initial phase angle for frequencies  $f + kf_{brg}$ .

By analogy to (5), the instantaneous power of motor operating with the bearings damage is the following:

$$p_{brg}(t) = i_{brg}(t)u(t) = p_0(t) + \frac{1}{2} I_1 U_1 \sum_{k=1}^K \left[ \begin{aligned} & I_{b1k} \cos[2\pi(2f - kf_{brg})t - \alpha_{b1k}] + \\ & I_{b2k} \cos[2\pi(2f - kf_{brg})t - \alpha_{b2k}] + \\ & I_{b1k} \cos(\alpha_{b1k}) \cos(kf_{brg} t) + \\ & I_{b2k} \cos(\alpha_{b2k}) \cos(kf_{brg} t) \end{aligned} \right]$$

Bearings damage leads to appearance in phase power spectra sideband components at frequencies  $2f - kf_{brg}$  and  $2f + kf_{brg}$ , and additional harmonic components at frequencies  $kf_{brg}$ .

By analogy, equations for detecting other frequently caused IM faults using instantaneous power signal analysis were given [14].

To verify effectiveness of proposed method, a series of experiments was done. Three identical induction motors of type АИР80В4У2, 1.5 kW, were used for testing. These motors were artificially damaged with three most frequently caused damage types: stator winding unsymmetry, rotor bar breaks and rotor eccentricity.

The tested motor used in the experimental investigation was a three-phase induction machine type AO 90 S-4, 50 Hz, 4-pole, 1.1 kW, 1410 rpm, 2.8 A. For investigation of turn-to-turn short circuit in stator windings, the taps were provided in one of the stator winding phases to imitate turn-to-turn short circuits

(Fig. 2, Table 1). For broken bars investigation several rotors of identical type with 1, 2, 3 or 4 broken bars, which can be interchanged, were used (Fig. 3). DC generator provided a mechanical load.

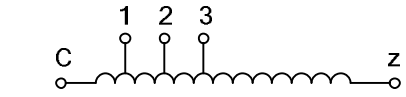

Figure 2 – Stator phase winding taps circuit

Table 1 – IM winding resistance measurement data

Phase	Resistance value, ohm		
A	7.576		
B	7.632		
C	7.66		
Taps in phase C	Winding part	Resistance value, ohm	Reduction of winding turns number, %
	1-z	7.45	2.74
	2-z	6.9	10
	3-z	6.31	17.6

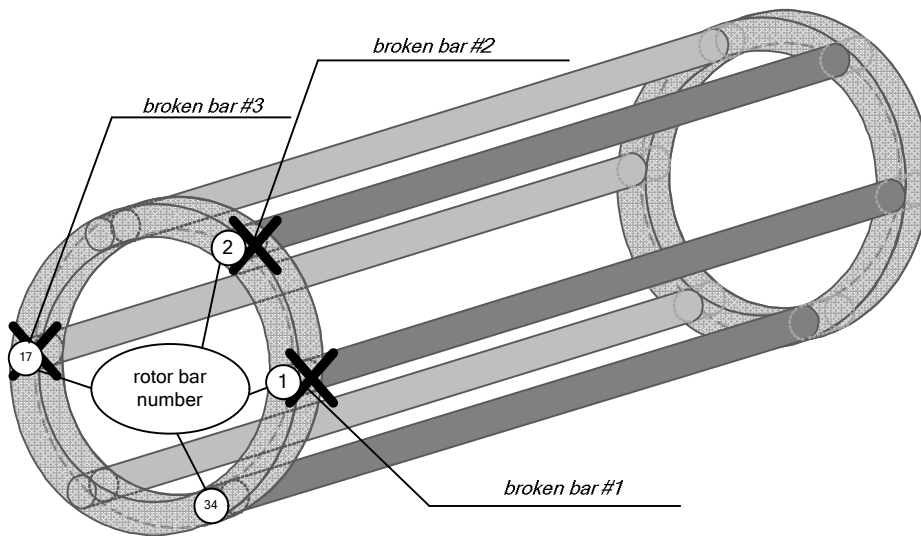

Figure 3 – Scheme of rotor apertures location:  
1, 2, 3, 4 are broken bar numbers.

Correspondence of the existing faults to the fulfilled experiments sequence number is shown in Table 2.

Table 2 – Experiments with IM artificial damages

No.	Fault type
1	IM basic variant without artificial defects
2	IM with a screwed-out bolt No. 1
3	IM with a screwed-out bolt No. 1 and phase C winding short circuit 2.74 %
4	IM with a screwed-out bolt No. 1 and phase C winding short circuit 10 %
5	IM with a screwed-out bolt No. 1 and phase C winding short circuit 17.6 %
6	IM with screwed-out bolts No. 1 and No. 2
7	IM with screwed-out bolts No. 1, No. 2 and winding short circuit 2.74 %
8	IM with screwed-out bolts No. 1, No. 2, No. 3 and No. 4

A measuring module and software were developed by authors [14] for measurement and record of electrical values (voltages and currents) necessary for the analysis (Fig. 4, 5).

The following assumptions were accepted for experimental researches. The possibility of load variation was not taken into account. This variation may lead to appearance of interharmonics and low-frequency harmonics in power spectra. Interharmonics do not make significant influence on informative harmonics which are used for analysis. The influence of low-frequency harmonics could be compensated by analysis of three-phase IM instantaneous power mean value. The influence of heating appears in changes of windings active resistances. In case of uniform heating the active resistances will change symmetrically. Nonuniform heating mainly leads to clearer asymmetry demonstration. It could be observed by difference between amplitude harmonics by phases. Researches [14] showed that the main influence of saturation appears on 6-th and its multiple harmonics of instantaneous power. However,

harmonics of lower frequencies were used in this work. It has to be mentioned, that offered method could be used both for variable speed motor and for fixed speed motor based on voltage inverter (with PWM).

Currents and voltages of phases were measured both under idle mode and full load mode, and then they were analyzed. Analysis results leads to the following conclusions (Fig. 6, 7).

Analysis gives the following results. All tested motors have basic mixed eccentricity, caused of motor disassembling and assembling operations. Further analysis showed, that both methods could be used for detecting different motor damages types, but amplitude values of current spectra harmonics related, for example, to stator unsymmetry, are too small (Fig. 6,b,d). Thus in order of incipient fault they could be wrong detected as a noise harmonics. In difference to this method, total 3-phase spectra analysis allows operate with clearly visible harmonics (Fig. 7,b,d). Moreover, this method allows get big number of additional harmonic components related to each damage type. This feature also allows avoid wrong diagnosis. Thus, instantaneous power spectra analysis is more reliable diagnostic method, which could be easily implemented at industrial enterprises and it doesn't need expensive equipment for implementation.

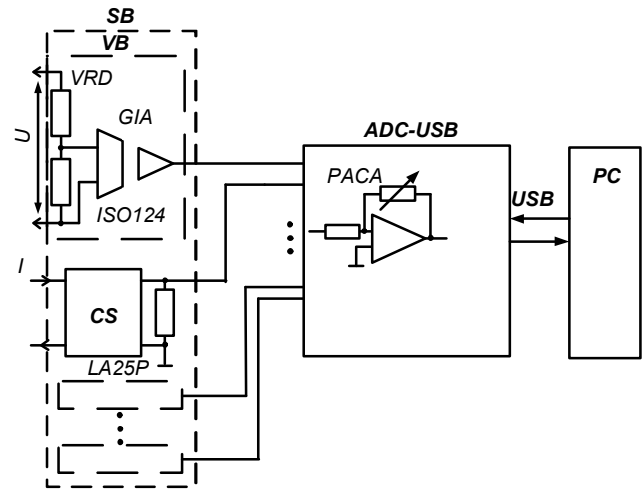

Figure 4 – Measuring module functional circuit:  
 SB – sensor block; VB – voltage block;  
 VRD – voltage resistance divider; GIA – galvanic isolation amplifier; CS – current sensor; PC – personal computer; PACA – programmed amplification coefficient amplifier; USB – PC bus

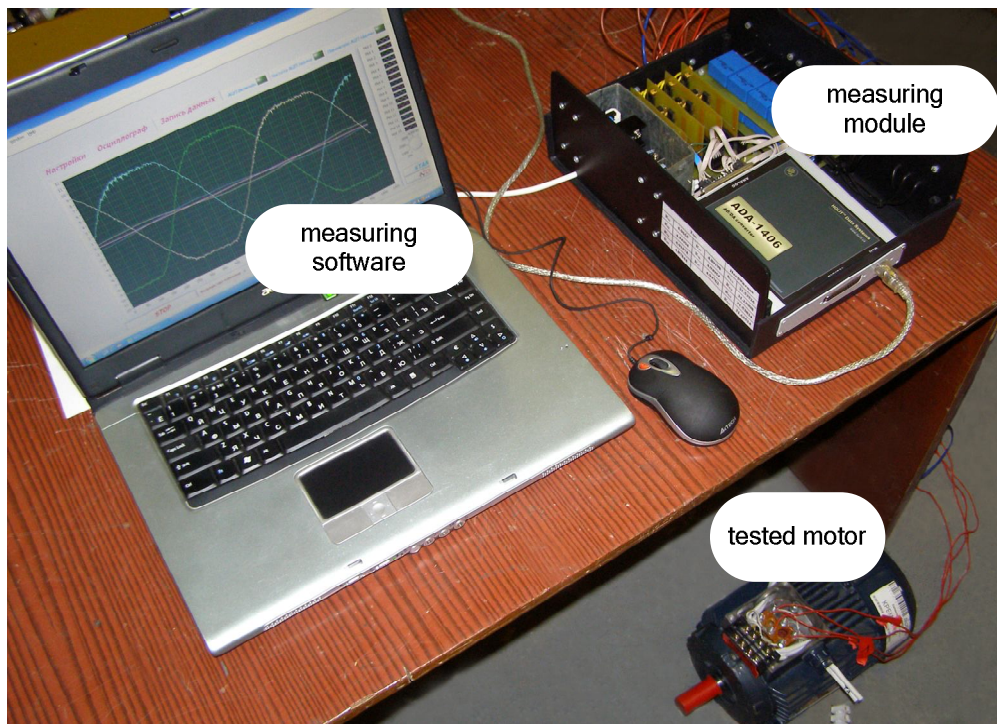

Figure 5 – Photo of the measuring complex

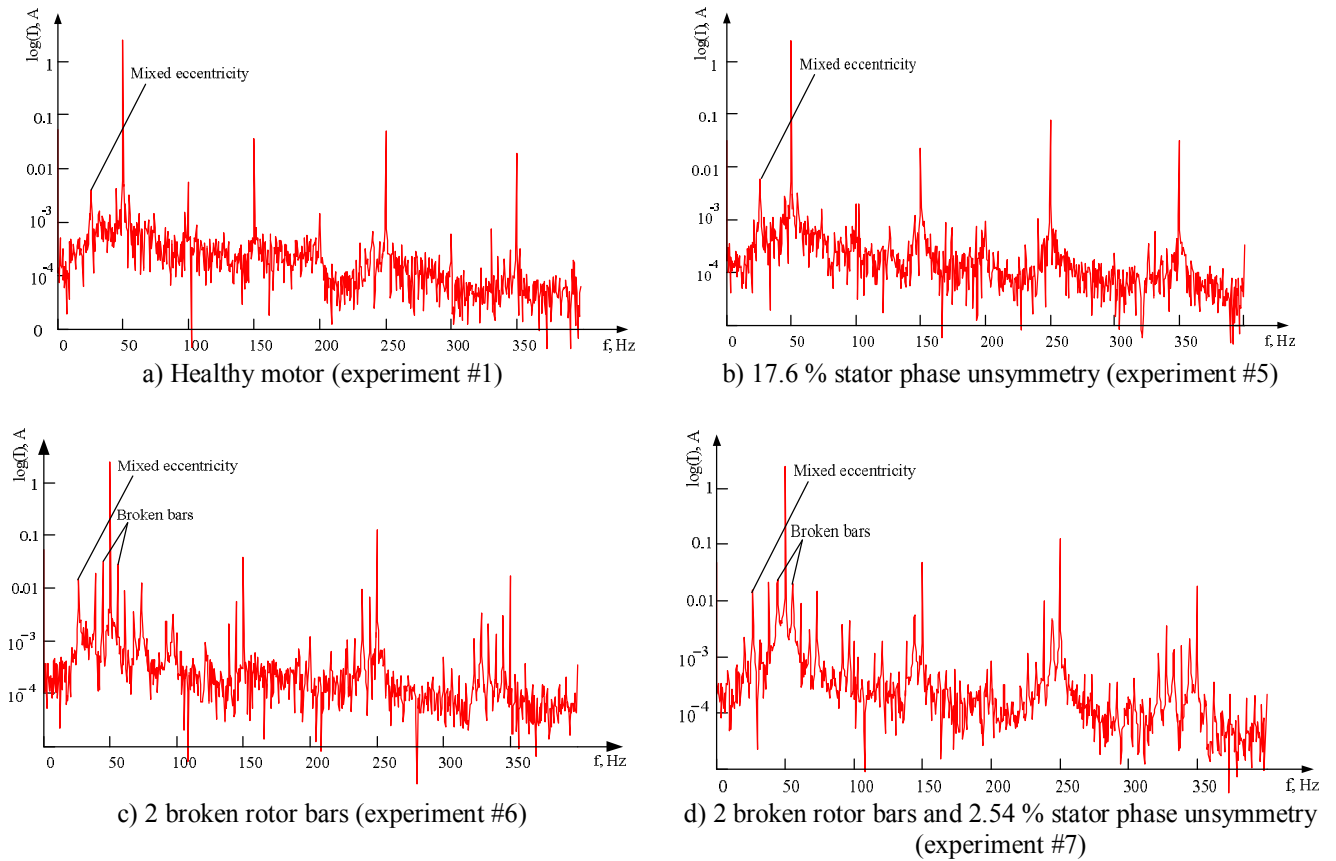

Figure 6 – Phase current

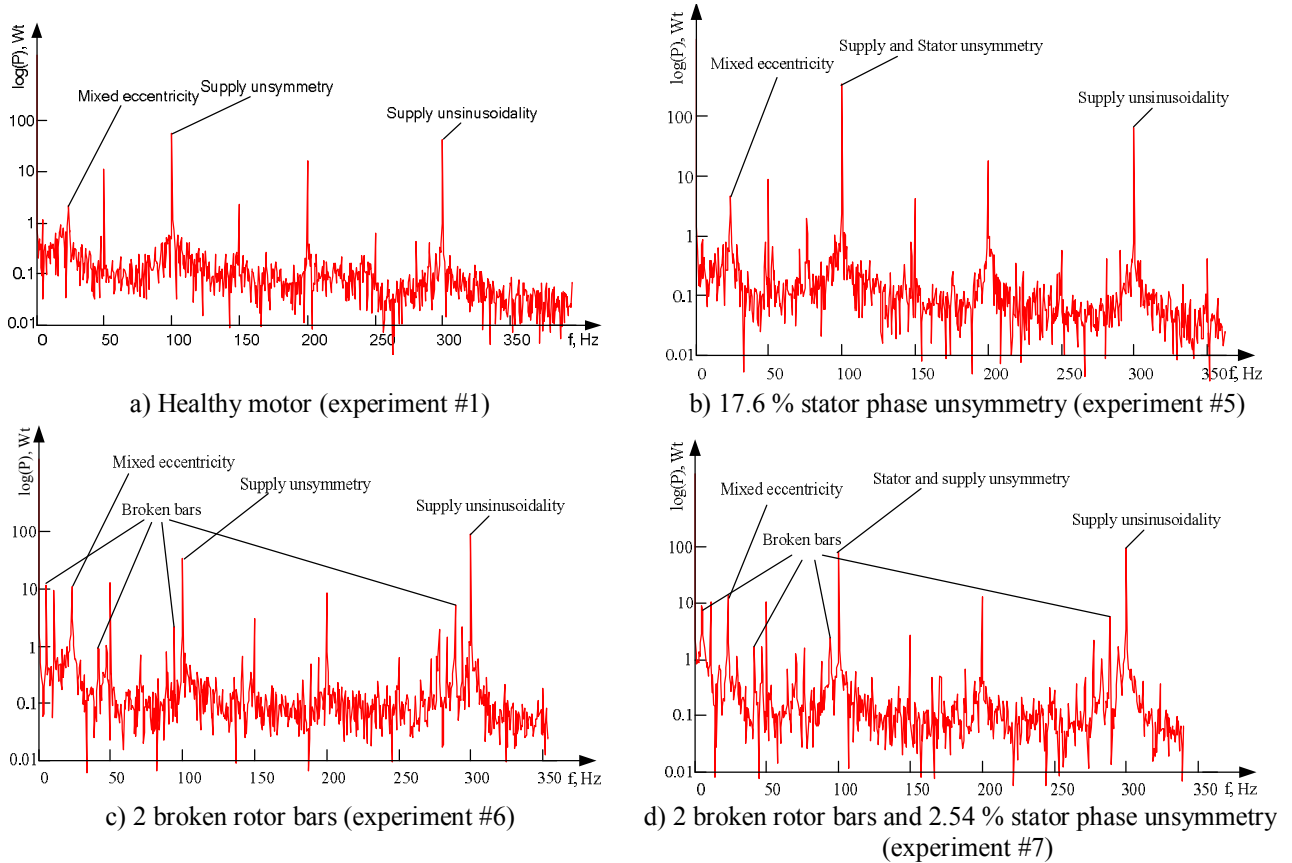

Figure 7 – Total three-phase power

**CONCLUSIONS.** In this article the advantages of usage the instantaneous power spectra analysis for IM fault detection were shown. This method provides additional diagnostic information by means of additional harmonic components which are proper for certain faults. This allows not only reliable detection of certain fault type, but also separation of some fault types presented in motor simultaneously.

In this paper the most frequent IM fault types were reviewed, and expressions for certain fault frequencies detection were given.

Analysis of experimental verification of the proposed method showed its advantages in spite of well-know methods, such as reliability, need relatively low-cost equipment for implementation, possibility to make comprehensive analysis of tasted motor.

#### REFERENCES

1. Thorsen, O.V. and Dalva, M. (1995), "A survey of faults on induction motors in offshore oil industry, petrochemical industry, gas terminals, and oil refineries", *IEEE Transactions on Industry Applications*, Vol. 31, no. 5, pp. 1186–1196.
2. Thorsen, O.V. and Dalva, M. (1999), "Failure identification and analysis for high-voltage induction motors in the petrochemical industry", *IEEE Transactions on Industry Applications*, Vol. 35, no. 4, pp. 810–818.
3. Benbouzid, M.E.H. and Kliman, G.B. (2003), "What stator current processing-based technique to use for induction motor rotor faults diagnosis?", *IEEE Transactions on Energy Conversion*, Vol. 18, no. 2, pp. 238–244.
4. Lee, H.H., Tu, N.N. and Min, K.J. (2005), "A study on decision tree for induction motor diagnostic system", *International Symposium on Electrical and Electronics Engineering (ISEE)*, Vol. 1, pp. xii–xvi.
5. Onel, I.Y., Dalci, K.B. and Senol, I. (2005), "Detection of outer raceway bearing defects in small induction motors using stator current analysis", *Sadhana*, Vol. 30, no. 6, pp. 713–722.
6. Drif, M., Benouzza, N., Bendiabdellah, A. and Dente, J.A. (1999), "The use of instantaneous power

spectrum in the detection of rotor cage faults on 3-Phase induction motors "ELECO '99". *International conference on electrical and electronics engineering*, pp. 351–355.

7. Legowski, S.F., Sadrul Ula, A.H.M. and Trzynadlowski, A.M. (1996), "Instantaneous power as a medium for the signature analysis of induction motors", *IEEE Transactions on Industrial Electronics*, Vol. 32, no. 4, pp. 904–909.

8. Trzynadlowski, A.M. and Ritchie, E. (2000), "Comparative investigation of diagnostic media for induction motors: a case of rotor cage faults", *IEEE Transactions on Industrial Electronics*, Vol. 47, no. 5, pp. 1092–1099.

9. Drif, M. and Cardoso, A.J.M. (2009), "The Use of the Instantaneous-Reactive-Power Signature Analysis for Rotor-Cage-Fault Diagnostics in Three-Phase Induction Motors", *IEEE Transactions on Industrial Electronics*, Vol. 56, no. 11, pp. 4606–4614.

10. Ibrahim, A., El Badaoui, M., Guillet, F. and Bonnardot, F. (2008), "A New Bearing Fault Detection Method in Induction Machines Based on Instantaneous Power Factor", *IEEE Transactions on Industrial Electronics*, Vol. 55, no. 12, pp. 4252–4259.

11. Drif, M. and Cardoso, A.J.M. (2008), "Airgap-Eccentricity Fault Diagnosis, in Three-Phase Induction Motors, by the Complex Apparent Power Signature Analysis", *IEEE Transactions on Industrial Electronics*, Vol. 55, no. 3, pp. 1404–1410.

12. Demirchian, K.S., Neiman, L.R. and Korovkin, N.V. (2009), *Theoretical Fundamentals of Electrotechnics: Handbook for higher educational establishments*, 5<sup>th</sup> edition, Vol. 2, Piter, St. Petersburg, Russia. (in Russian)

13. Rodkin, D.I. (2004) "New system of electric energy quality coefficients", *Naukovyi visnyk NGU*, no. 3, pp. 20–26. (in Russian)

14. Zagirnyak, M.V., Mamchur, D.G. and Kalinov A.P. (2012), "The theory and application of the induction motor diagnostic methods based on electrical signal analysis", *Journal of Energy Technology (JET)*, Vol. 5, no. 2, pp. 37–50.

#### АНАЛИЗ СПЕКТРА МГНОВЕННОЙ МОЩНОСТИ КАК МЕТОД ДИАГНОСТИКИ ПОВРЕЖДЕНИЙ РОТОРА И СТАТОРА АСИНХРОННОГО ДВИГАТЕЛЯ

**Д. Г. Мамчур**

Кременчугский национальный университет имени Михаила Остроградского  
ул. Первомайская, 20, г. Кременчуг, 39600, Украина. E-mail: dm@kdu.edu.ua

Предложен метод диагностики технического состояния асинхронных двигателей на основе анализа спектра сигнала мгновенной мощности. Данный метод привлекателен благодаря простоте измерений сигналов, необходимых для анализа, а также более надёжными результатами диагностики по сравнению с другими известными методами. Представлены математические выражения, устанавливающие связь между частотами дефектов в сигнале мощности и наиболее распространёнными типами дефектов. Для подтверждения работоспособности предложенного метода представлены экспериментальные результаты, полученные на лабораторном оборудовании и испытываемых двигателях с искусственно созданными повреждениями. Результаты экспериментов подтвердили надёжность предложенного метода и возможность разделения одновременно существующих дефектов разных типов на основе анализа спектра мощности двигателя. Представленные теоретические результаты могут быть применены в промышленности при создании надёжных и недорогих систем диагностики асинхронных двигателей средней и малой мощности.

**Ключевые слова:** диагностика, асинхронный двигатель, анализ сигнала мощности.

Стаття надійшла 11.09.2013.